

**Montageanleitung für Ganzmetall-Drehboden**  
 Art.Nr.006710, 006711 in Verbindung mit Beschlag Art.Nr.006424 / 006430

**Mounting instruction for metal 270° pie cut basket,**  
 art.no.006710, 006711 with axle, art.no.006424 / 006430

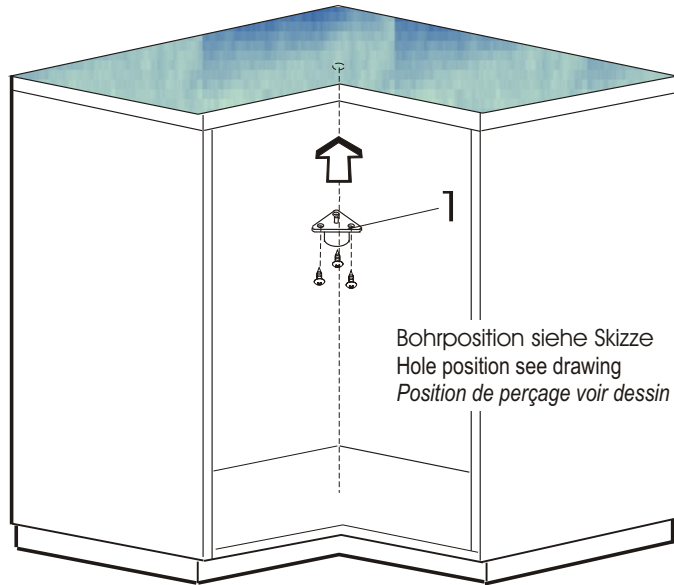



**Instructions d'assemblage pour corbeille 3/4 ronde,**  
 art.no.006710, 006711 avec axe, art.no.006424 / 006430

**A.**

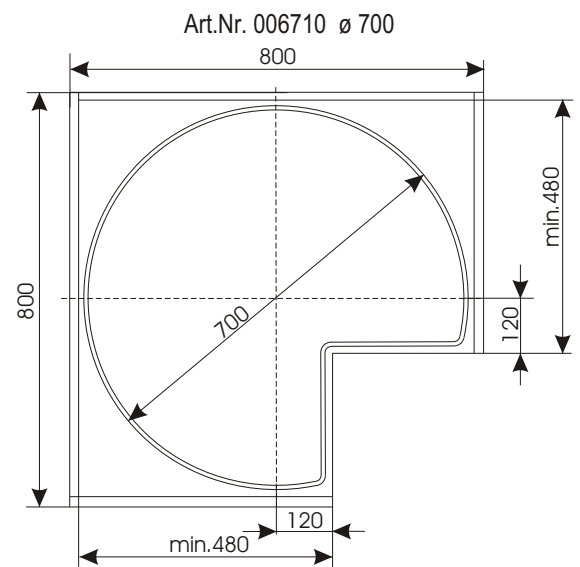
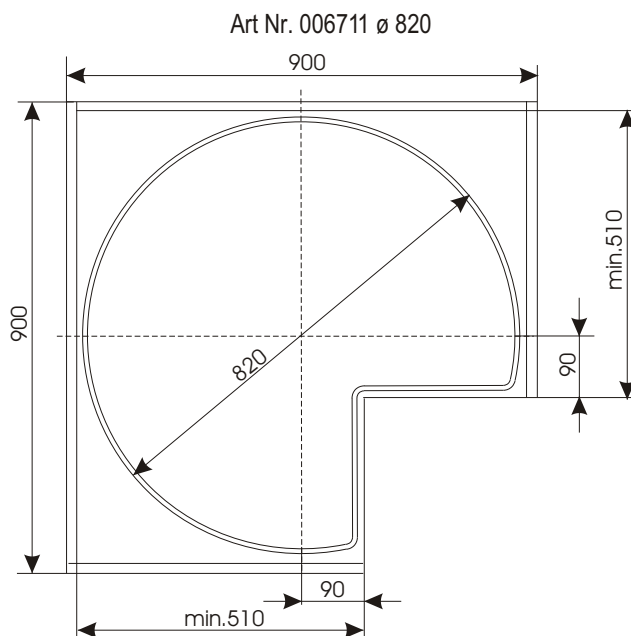

Bohrposition siehe Skizze  
 Hole position see drawing  
 Position de perçage voir dessin



5	Drehboden / pie cut basket / corbeille		2
4	Zylinderstift / straight pin / goupille cylindrique		2
3	Auflager mit Bremse / bearing with brake / coussinet avec frein		2
2	Mittelachse Art.Nr.006424 oder 006430 / axle, art.no.006424 or 006430 / axe, art.no.006424 ou 006430		1
1	Lagerbock ,oben / upper pivot bracket / palier supérieur		1
Pos.	Benennung / description / dénomination		Stck / pce

## B.

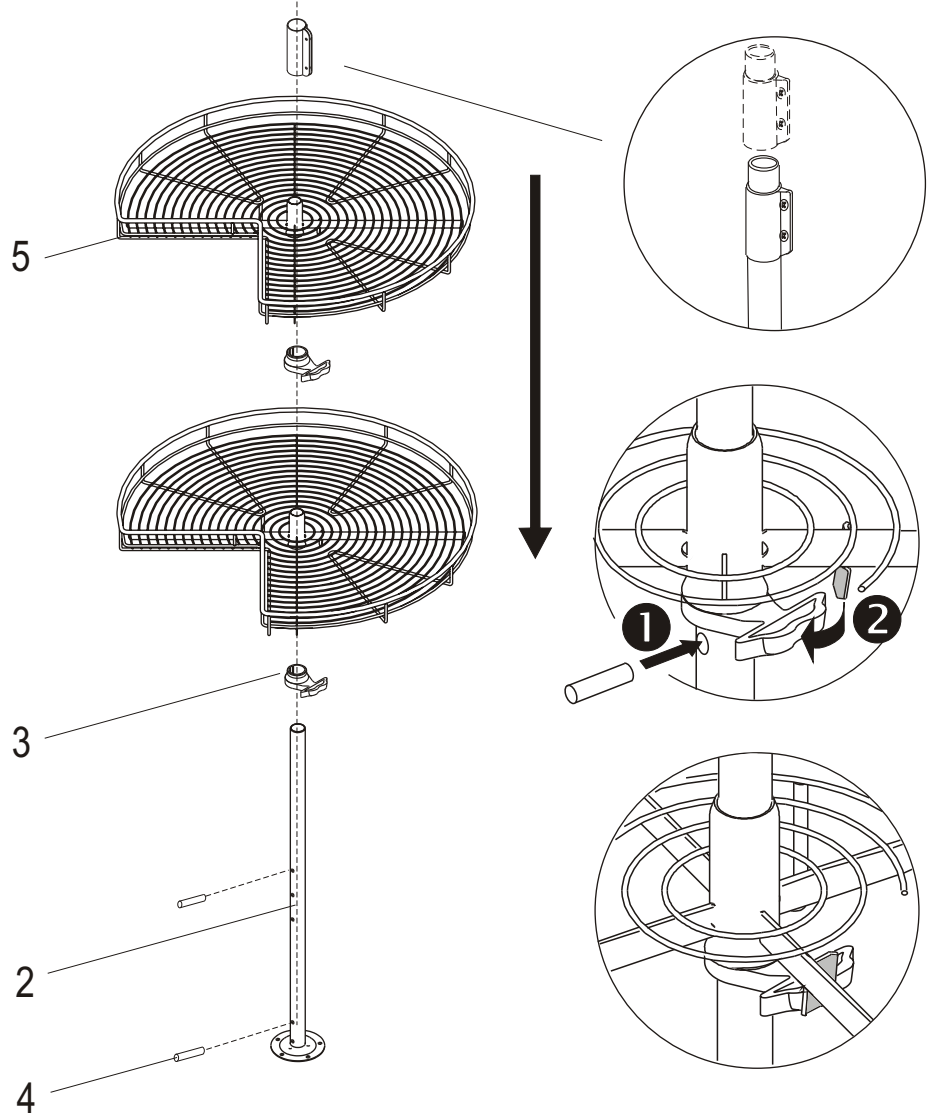

## C.

